



ENGINEERED TO GLOBAL STANDARDS

Molygraph is India's leading engineered lubricants company. For over 32 years we have mastered the art and science of making high quality specialty lubricants, for various industries and applications. At the core of each of our products lies our strong emphasis on Research and Development. Coupled with it comes an extensive understanding of our client's businesses, which helps us develop the right solutions for each of our clients.

Apart from developing international quality products we put special focus on customer service. We prefer to solve problems rather than sell products, create value instead of focusing on margins and build long term relationships in place of client acquisitions.

Behind each of our products lies our strong unwavering passion to surpass global standards by continuously investing in intensive R&D.

It is the quality of our products and service that has made us one of the only Indian companies to have pan-India presence along with some of the most reputable industrial houses as partners.

GLOBAL PRESENCE

ASIA - AFRICA - SOUTH AMERICA

AUTHORISED DISTRIBUTORS



Anand Engineers Pvt. Ltd.
 66 M.I.D.C., Road No. 13,
 Andheri (E), Mumbai 400 093. INDIA.
 T : +91 22 2821 9292 / 98 / 99 | F : +91 22 2837 9337
 E : sales@molygraph.com | W : www.molygraph.com

CORE EXPERTISE



PRODUCT LINE

- Speciality Lubricants
- Hot Forging Lubricants
- Metal Working Fluids
- Metal Forming Lubricants
- Cleaners & Degreasers
- Rust Preventives
- Thread Dope Compounds
- Maintenance, Repairs & Operation Products



APPLICATION AREAS

- Bearings
- Gears
- Conveyor Chain
- Nuts & Bolts
- Metal Cutting
- Metal Forming
- Deep Drawing



BUSINESS VERTICALS

- Automotive
- Drawing & Pressing
- Food & Pharma
- Forging
- Metal Working
- Mining
- Off shore & On Shore Drilling
- Punching & Stamping
- Steel

PAN INDIA MARKETING AND DISTRIBUTORS NETWORK

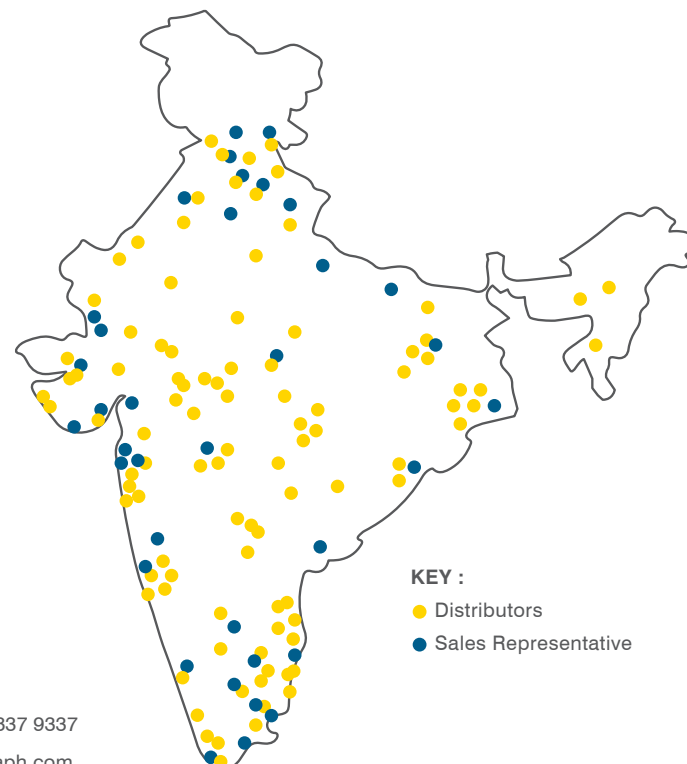

GENERAL ENGINEERING

Customised range of General Engineering Lubricants



**GLOBAL STANDARDS
 CUSTOMIZED SOLUTIONS
 UNPARALLELED SERVICE**

www.molygraph.com

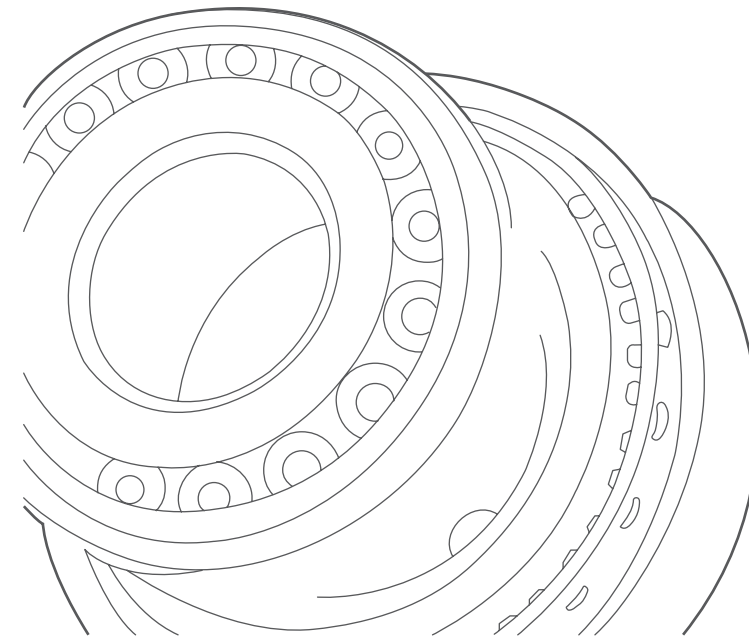
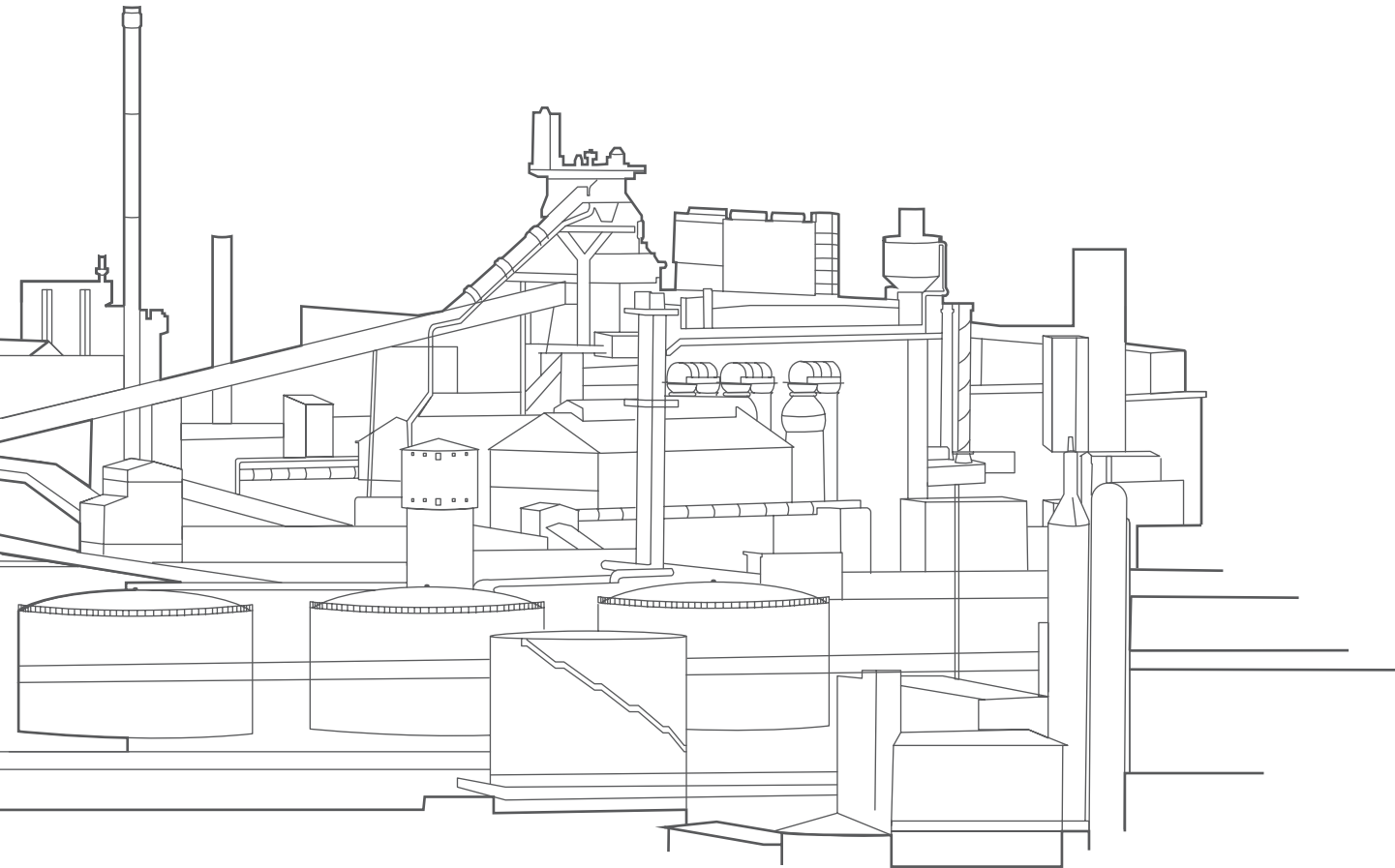

GENERAL ENGINEERING

The General Engineering division at Molygraph offers a range of speciality lubricant solutions for Industrial Electrical and Mechanical Maintenance. Molygraph has tailored solutions for bearings, chains, slides, wire ropes, gears, nuts and bolts and many other applications that are routinely exposed to harsh and severe conditions. Molygraph also has a range of lubricants which have been specially developed for food grade applications and are NSF-H1 certified. Molygraph's MRO range comprises of a comprehensive range of greases, rust preventives, cleaners and degreasers, multipurpose lubricants and Crack Detection Kits which are available in bulk and aerosol form for optimised application and ease of use.

Molygraph's specialised formulations provide extended relubrication intervals and longer component life and thus ensure a more effective scheduled maintenance program.

Molygraph products are available in a wide variety of packing options. From 180 kg drums to 25 kg / 20 kg pails to 1 kg Jars we have the right pack size to suit your needs.

O1 | GREASES & PASTES

EXTREME PRESSURE GREASES

Molygraph offers a full range of high performance greases for general applications that easily outperform conventional greases. These greases are fortified with solid lubricants, EP and AW additives. They reduce friction, wear and tear and offer good rust protection, that results in the reduction of overall maintenance costs.

 Suitable for bearings and sliding mechanisms subjected to extreme pressures and high loads.

PRODUCTS	THICKENER	BASE OIL	NLGI GRADE	DROPPING POINT (°C)	OPERATING TEMPERATURE (°C)
BRB 30	Lithium	Mineral	#2	+ 180	-20/+140
TFG 100	Lithium Complex	Mineral	#2	+ 260	-20/+160
SUPER GREASE EP 2	Lithium	Mineral	#2	+ 180	-20/+120

HIGH TEMPERATURE GREASES

Conventional greases cannot withstand continuous high operating temperatures. Molygraph's specially formulated grease chemistries give unsurpassed performance in critical high temperature applications. These greases provide superior oxidation properties, and high thermal stability.

 Hot air blowers, conveyor chains bearings, furnace door hinges and applications exposed to high temperatures and corrosive atmospheres.

PRODUCTS	THICKENER	BASE OIL	NLGI GRADE	DROPPING POINT (°C)	OPERATING TEMPERATURE (°C)
EHT (MOD)	Inorganic	Mineral	#2	Non-Melt	-20/+180
PUG 9000 H	Polyurea	Mineral	#2	+ 270	-20/+180
SGHT 600	Special Carbon	Synthetic	#2	Non-Melt	-20/+600
UNIFLOR 4622R	PTFE	PFPE	#2	Non-Melt	-20/+250
NYECORR 140	PTFE	PFPE	#2	Non-Melt	-20/+250
ULTRASYN ES 3000	Inorganic	Synthetic	#2	Non-Melt	-20/+200

WATER RESISTANT GREASES

Water ingress is always a factor in heavy industrial applications. Conventional greases are easily washed out resulting in frequent lubrication and high maintenance downtime. Molygraph's range of water resistant greases have excellent water washout properties, are resistant to coolants and provide good protection against rust and corrosion.

 Bearings, gear couplings and applications where water resistance is required.

PRODUCTS	THICKENER	BASE OIL VISCOSITY @ 40°C (cSt)	NLGI GRADE	DROPPING POINT (°C)	OPERATING TEMPERATURE (°C)
SG 120	Lithium Calcium	120	#2	+ 180	-30/+140
SG 150	Lithium Calcium	150	#2	+ 180	-20/+140
SG 180	Lithium Calcium	180	#2	+ 180	-20/+140
SG 500	Lithium Calcium	500	#2	+ 180	-20/+140
SG 1000	Lithium Calcium	1000	#2	+ 180	-20/+140

MULTIFUNCTIONAL GREASES

Industrial applications contain a multitude of conditions and factors that pose a challenge to effective lubrication. Wide temperature ranges, high loads, water ingress, humidity and other extreme conditions can lead to lubrication failure. Molygraph has developed a range of Multifunctional greases that can withstand these challenging conditions and provide unparalleled performance.

 Bearings and sliding surfaces exposed to heavy loads, water ingress and wide temperature range.

PRODUCTS	THICKENER	BASE OIL VISCOSITY @ 40°C (cSt)	NLGI GRADE	DROPPING POINT (°C)	OPERATING TEMPERATURE (°C)
MFG 220	Lithium Complex	220	#2	+ 260	-20/+160
MFG 460 EP	Lithium Complex	460	#2	+ 250	-20/+160
SGH 100 S	Calcium Sulfonate Complex	100	#2	+ 300	-20/+180
MPG-2 RED	Lithium Complex	150	#2	+ 260	-20/+160
ULTRATAK MILL GREASE 460	Calcium Sulfonate Complex	460	#3/2	300	-20/+180
LSG 33	Lithium	100	#2	180	-40/+200

GREASES FOR CENTRALISED LUBRICATION SYSTEMS

Enclosed gearboxes, motors and other critical systems have a centralised lubrication mechanism. Normal greases have low pump ability and are thus unsuitable. Molygraph has a range of highly pumpable fluid greases that provide long life lubrication, good rust and corrosion protection and excellent water resistance.

 Centralised Lubrication Systems.

PRODUCTS	THICKENER	BASE OIL	NLGI GRADE	OPERATING TEMPERATURE (°C)
MPG EPLF 0	Lithium	Mineral	#0	-20/+120
MPG EPLF 00	Lithium	Mineral	#00	-20/+120
MPG EPLF 000	Lithium	Mineral	#000	-20/+120

CHAIN & WIRE ROPE GREASE

Lubrication of wire ropes is essential to promote longer service life and low maintenance costs. Molygraph's wire rope lubricants reduce friction between strands and rope bends. They also protect strand surfaces against rust and corrosion due to its resistance to water and emulsification.

 Wire Ropes and Chains.

PRODUCTS	THICKENER	BASE OIL	NLGI GRADE	DROPPING POINT (°C)	OPERATING TEMPERATURE (°C)
CRG 100 GRADE 1	Lithium	Mineral	1	180	-10/+140



OPEN GEAR GREASES

Open gears require specialised lubricants that withstand heavy loads, have enhanced adhesion and carefully selected solid lubricants. Our open gear greases prevent squeeze out and overcome pitting corrosion. They also contain additives to withstand extreme pressure and high loads.

PRODUCTS	THICKENER	BASE OIL VISCOSITY @ 40°C (cSt)	NLGI GRADE	FOUR BALL WELD LOAD (KG)	OPERATING TEMPERATURE (°C)
OGG 1750	Metal Complex	1250	#2/3	800	-20/+150
OGG 2500	Metal Complex	2500	#2	800	-20/+150
SPRAYLUBE 1250	Aluminium Complex	1250	#00	800	-25/+180
SPRAYLUBE 2500	Aluminum Complex	2500	#00	800	-25/+180

THREADS, NUTS & BOLTS

Threaded connections, nuts and bolts operating under high pressure and temperature tend to seize if effective lubrication is not provided. Molygraph's antisieze compounds with a blend of different solid lubricants provides excellent anti seize and load carrying characteristics at high temperatures. It prevents threaded parts from galling, distortion and breaking. It also guards against rust and fretting corrosion.

PRODUCTS	BASE OIL	SOLID LUBRICANT	SURFACE AREA COVERAGE (KG/M ²)	OPERATING TEMPERATURE (°C)
AS 10	Mineral	MoS ₂	40-45	-30/+450
AS 60  - Molytack	Mineral	MoS ₂	45-50	-30/+450
KOPAL®  - Kopalube	Mineral	Copper	45-50	-20/+1100
KOPAL® 1000	Synthetic	Copper	40-45	-20/+1100

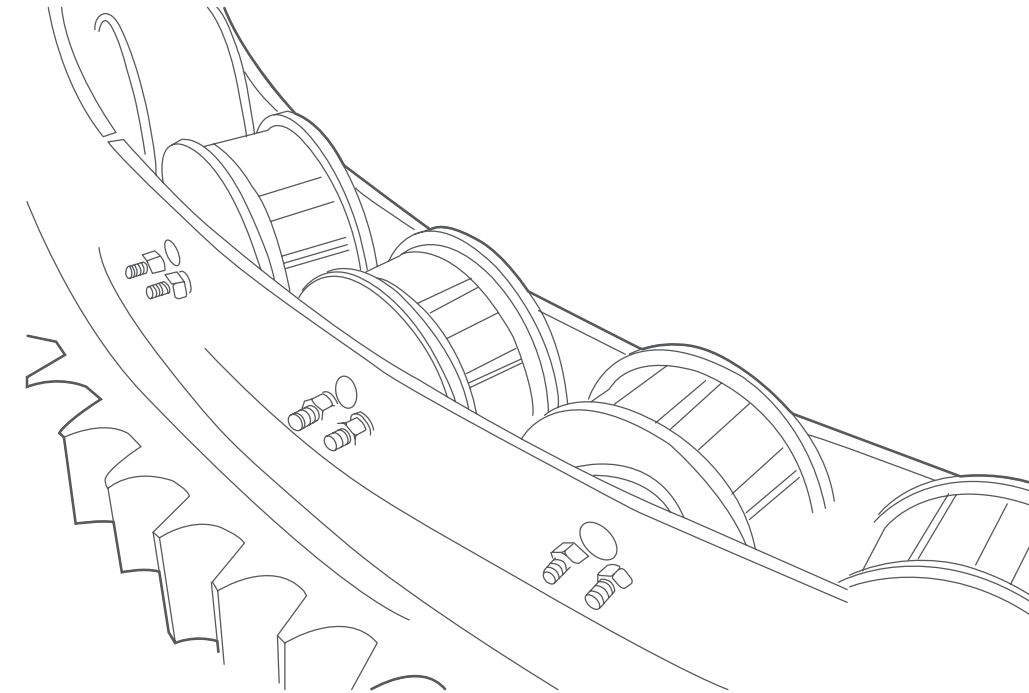

O2 | LUBRICATING OILS

GEAR OILS

Industrial gear oils are expected to perform under conditions of high heat and heavy loads, and in environments often contaminated with dirt, debris and water. To combat these difficult conditions Molygraph offers a range of gear oils in different chemistries & viscosities, specially formulated for lubrication of enclosed gear boxes.

 Enclosed Gear Boxes.

PRODUCTS	BASE OIL	FLASH POINT (°C)	POUR POINT (°C)	COPPER CORROSION (RATING)
SUPER GEAR OIL 100/150/220/320/460	Mineral	+ 220	- 20	1b
ULTRAGEAR GLIDE 150/220/320/460/680	Mineral + Liquid MoS ₂	+ 220	- 20	1a
ULTRAGEAR SYN 150/220/320/460/680/1000	PAO	+ 240	- 42	1b
GEAR OIL PG 150/220/320/460/680/1000	Polyglycol	+ 270	- 20	1a

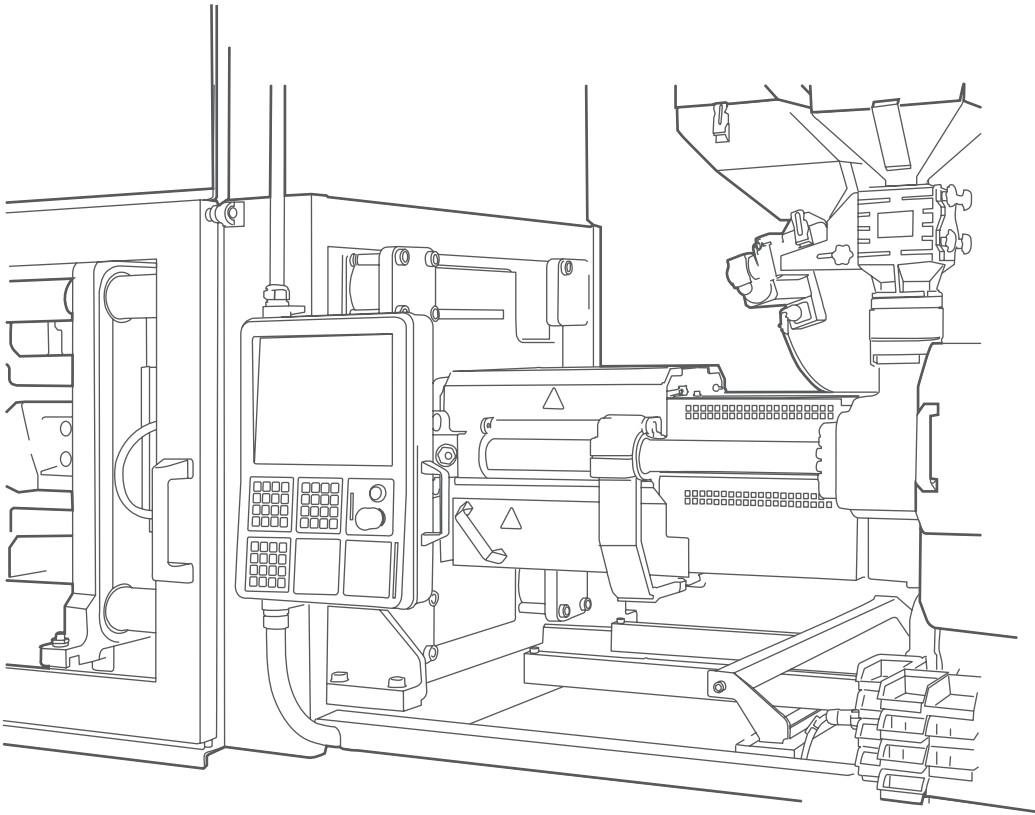

CONVEYOR CHAIN OILS

Molygraph's Stenol series of conveyor chain oils are able to meet the demanding requirements of chain lubricants and prevents residue build-up and offers effective lubrication with low evaporation at high temperatures. They also increase the life of the chain.

 Conveyor Chains.

PRODUCTS	BASE OIL	BASE OIL VISCOSITY @ 40°C (cSt)	FLASH POINT (°C)	COPPER CORROSION (RATING)
STENOL 50  - CHAINLUBE 50	Synthetic	175	280	1a
STENOL 220	Synthetic	220	280	1a

FOOD GRADE OILS





The SAFOL range of food grade NSF H1 certified gear oils and general lubrication oils have been a mainstay for the lubrication of gears, bearings and other sliding surfaces which have incidental food contact. Carefully formulated with special additives these oils give unmatched lubrication.

PRODUCTS	BASE OIL	FLASH POINT (°C)	OPERATING TEMPERATURE (°C)
SAFOL® GEAR OILS 150/220/320/460	Synthetic	260	-40/+220
SAFOL® LUBRICATING OILS - 22/32/46/68/100	Synthetic	260	-40/+220

O3 | ELECTRICAL & MECHANICAL MAINTENANCE PRODUCTS











GALVANISED COATINGS

Molygraph's range of galvanised coatings have been carefully formulated.

PRODUCTS	APPLICATIONS
ZINCKOTE 	Zinc based cold galvanised coating. Contains high purity zinc providing excellent adhesion and cathodic protection on substrate metals as well as protection from sea water corrosion.  Equipment and installations exposed to corrosive atmosphere.
ALKOTE 	Bright aluminum based coating. High purity aluminum provides outstanding cathodic protection as well as resists to temperatures as high as 600°C. Excellent protection against salty and humid environment.  Equipment and installations exposed to corrosive atmosphere.

MULTIPURPOSE LUBRICANTS







Molygraph has an extensive range of lubricants used for maintenance and repair of day to day operating equipment. Our range of oils, sprays, bonded coatings and silicone compounds have been extensively used in challenging conditions and applications and have helped industries in considerable reduction in maintenance downtime and decreased costs.

PRODUCTS	DESCRIPTON	BENEFITS
EASY LUBE 	Multifunctional Lubricant	Excellent penetrating property. Loosens rust, carbon, dirt etc. Single multifunctional product that cleans, penetrates, lubricates and provides corrosion protection.  Dismantling of jammed bolts, nuts, screws, links, chains, hinges, valves and host of other electro mechanical fittings.
ECOSIL 	Silicone based Mold Release	Excellent penetration in hard to reach areas, non-staining and non corrosive and odourless. Low downtime creates increased production efficiency.
ITC BOND 	MoS ₂ Bonded coating	Reduces friction and wear in high pressure sliding surfaces. Prevents seizures at high temperatures and threads from galling. Resists fresh and salt water corrosion.  Gears, racks and pinions, splineshafts, plain bearings and threaded parts.
GRAPHITE SPRAY 	Graphite Based Bonded coating	A fine blend of colloidal graphite with synthetic resin binder. Excellent performance at elevated temperatures, high pressures and loads.  Valves, cams, slides, guideways, chutes, rails, tracks.
HVG 7	Silicone Based Mold release Compound	An effective release agent for complex rubber and plastic molds. Excellent resistance against chemicals and moisture.  Mold release in plastic and rubber parts
HVG 14	Di-electric Compound	Excellent di-electric strength. Prevents electrical shocks and flash overs. Has an extremely low dissipation factor.  High voltage line insulators, switches, battery terminals, cable connections, threaded connections in instruments.
HVG 21	High Vaccum Compound	Low volatility & vapour pressure of base. Has very good sealant properties and excellent chemical resistance. It can withstand high pressure of 10 ⁻⁶ torr.  Sealant and lubricant for glass joints, stop cocks, plug valves, o rings, seals and gaskets.
HVG 28/6	Valve & Tap Grease	Non-toxic and acts as a strong adhesive sealant. Offers excellent resistance to solvents, as well as hot and cold water.  Valves & taps used in chemical industries, as well as hot and cold water lines.

RUST PREVENTIVES

Molygraph has developed a range of rust preventives that have given excellent performance in industrial applications. From heavy duty corrosion protectors to solvent based chemistries, we have every industrial application covered. Molygraphs corrosion protectors displace moisture effectively and thus provide protection from rust, corrosion abrasion and scratches.



 Machine parts, forging components, cutting tools, machined components, precision tools.

PRODUCTS	FILM TYPE	CORROSION TEST	PROTECTION PERIOD (MONTH)
NEVERUST 20 	Oily non-drying film	200 hrs salt spray	10-12
NEVERUST 30 	Dry waxy film	200 hrs salt spray	10-12
NEVERUST 235 	Clear transparent and dry film	720 hrs humidity test	8-10
NEVERUST 530 	Solvent based Ultrathin soft film	720 hrs humidity test	6-8
NEVERUST 532 	Solvent based Ultrathin greasy film	570 hours salt spray test	12-14
ECOLUBE 	Thin and Oily	100 hours salt spray test	8-10

CLEANERS, DEGREASERS & ANTISPATTERS

Safe and effective cleaning should be a mainstay for industrial cleaners and degreasers. Molygraph's range of cleaners, degreasers and anti-spatters have been a benchmark in the MRO industry. Our range of solvent and water based chemistries have been tailored to meet the demanding needs of customers and are suitable for a variety of applications.



 Cleaning of electro mechanical assemblies, dies, molds, bearings and various other components.

PRODUCTS	DESCRIPTON
ECOKLEEN	Water based eco friendly cleaner
U-KLEEN F/E 	Fast evaporating universal cleaner & degreaser
SAFEKLEEN 	Online Cleaner & Degreaser
RUSTKLEEN 	Rust Cleaner
E-KLEEN 	Heavy duty electrical contact cleaner
EASYCLEAN 	Electric & Electronic contact cleaner
ASS 2265 	Anti-Spatter

CRACK DETECTION KIT

The CDK kit developed by Molygraph helps in the detection of microscopic cracks upto 10 micron on metals that cannot be seen with naked eyes. The application is completely non-destructive by nature and due to extremely low chlorine and sulphur contents these products can be used safely on stainless steel, nickel, monel and other exotic metals.

 Detection of surface flaws on dies, molds, tools, jigs and welds on pressure vessels subjected to thermal cycles.

PRODUCTS	DESCRIPTON
CDK 10 	Cleaner
CDK 20 	Dye Penetrant
CDK 30 	Developer